

SUBMITTAL DATA SHEET

No-Lead Threaded Bronze Pipe Fittings Bronze Tee

72230



A.Y. McDonald Mfg. Co. No-Lead Threaded Pipe Fittings are constructed from heavy duty bronze and are rated for commercial, industrial and residential applications up to 125 WOG.

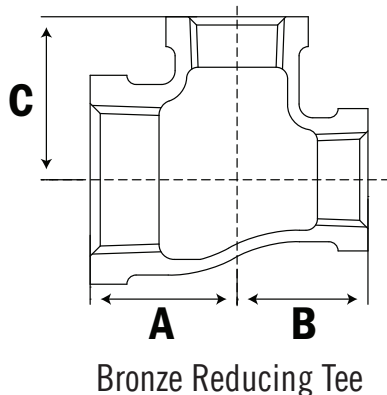
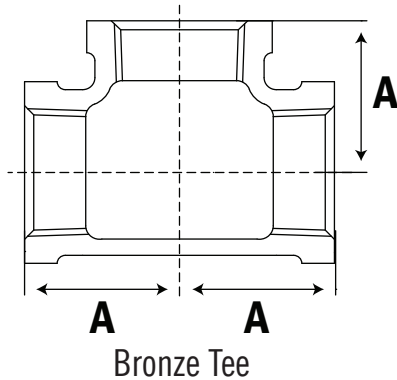

Model Number	Size	Dimensions A	Carton Qty	Weight Per Pcs.
72230	1/8	0.55	5	0.08
72230	1/4	0.71	5	0.12
72230	3/8	0.83	5	0.21
72230	1/2	1.02	5	0.31
72230	3/4	1.18	5	0.52
72230	1	1.42	5	0.86
72230	1 1/4	1.69	5	1.29
72230	1 1/2	1.85	5	1.67
72230	2	2.13	5	2.73
72230	2 1/2	2.72	1	4.31
72230	3	3.07	1	6.42
72230	4	3.78	1	12.13

Model Number	Size	Dimensions			Carton Qty	Weight Per Pcs.
		A	B	C		
72230	1/2 x 1/4	0.87	0.87	0.87	5	0.23
72230	1/2 x 3/4	1.11	1.11	1.08	5	0.35
72230	3/4 x 1/4	1.05	1.00	1.08	5	0.45
72230	3/4 x 1/2	1.06	1.08	1.10	5	0.41
72230	3/4 x 1/2 x 1/2	1.06	1.02	1.10	5	0.35
72230	3/4 x 1/2 x 3/4	1.18	1.10	1.18	5	0.38
72230	3/4 x 1	1.31	1.31	1.30	5	0.72
72230	1 x 1/4	1.11	1.11	1.22	5	0.61
72230	1 x 1/2	1.18	1.20	1.22	5	0.63
72230	1 x 1/2 x 1	1.42	1.22	1.42	5	0.61
72230	1 x 3/4	1.30	1.18	1.30	5	0.71
72230	1 x 3/4 x 3/4	1.30	1.18	1.30	5	0.54
72230	1 x 3/4 x 1	1.42	1.30	1.42	5	0.71
72230	1 1/4 x 1/2	1.30	1.29	1.42	5	0.78
72230	1 1/4 x 3/4	1.38	1.39	1.50	5	0.91
72230	1 1/4 x 1	1.54	1.52	1.61	5	0.93
72230	1 1/2 x 3/4	1.42	1.42	1.61	5	1.45
72230	1 1/2 x 1	1.54	1.55	1.73	5	1.20
72230	1 1/2 x 1 1/4	1.73	1.72	1.81	5	1.31
72230	2 x 1/2	1.49	1.49	1.88	5	1.83
72230	2 x 3/4	1.46	1.47	1.85	5	1.51
72230	2 x 1	1.57	1.59	1.97	5	1.76
72230	2 x 1 1/4	1.77	2.04	2.05	5	1.84
72230	2 x 1 1/2	1.89	1.89	2.09	5	2.08
72230	3 x 2	2.52	2.52	2.87	1	4.15

SUBMITTAL INFORMATION

- Standards

NSF/ANSI 61-4 & NSF/ANSI 372
 ASTM B584 UNS Alloy C89833 (Casting)
 ASME B16.15 (Dimensions)
 ANSI/ASME B1.20.1 (Threads)

- Markings

Manufacturer's logo, Size, Country of Origin, "NL"

NO-LEAD: The weighted average of the wetted surface of this no-lead product contacted by consumable water contains less than one quarter of one percent (0.25%) lead.



A.Y. McDonald Mfg. Co.
 4800 Chavenelle Rd
 Dubuque, IA 52002

Toll Free: 1-800-292-2737
 sales@aymcdonald.com
 aymcdonald.com

A.Y. McDonald considers the information on this assembly drawing correct when published. Item and option availability, including specifications, are subject to change without notice.

Submitted by: