

816 Series OS&Y UL/FM Resilient Seated Gate Valve 2" - 12", Flanged Ends

SPECIFICATIONS

- Complies w/ AWWA C515 STANDARD
- HEAVY DUTY HANDWHEEL AND ATTACHMENT NUT
- HIGH QUALITY GRAPHITE STEM SEAL
- NPT PLUG ON BODY
- FLANGES TO ANSI B16.1 CLASS 125 (OTHER FLANGE TYPES AVAILABLE ON REQUEST)
- UL LISTED AND FM APPROVED
- CERTIFIED TO NSF/ANSI 61 & 372

WORKING PRESSURE 300 PSI

WORKING TEMPERATURE 42°F TO 180°F

CORROSION PROTECTION

- FUSION BONDED EPOXY COATED INTERIOR AND EXTERIOR TO AWWA C550 STANDARD

INSTALLATION

- VALVES INSTALLED IN HORIZONTAL PIPING SYSTEMS SHOULD HAVE THE STEMS ORIENTED VERTICALLY
- VALVES INSTALLED IN VERTICAL PIPING SYSTEMS SHOULD HAVE THE STEMS ORIENTED HORIZONTALLY

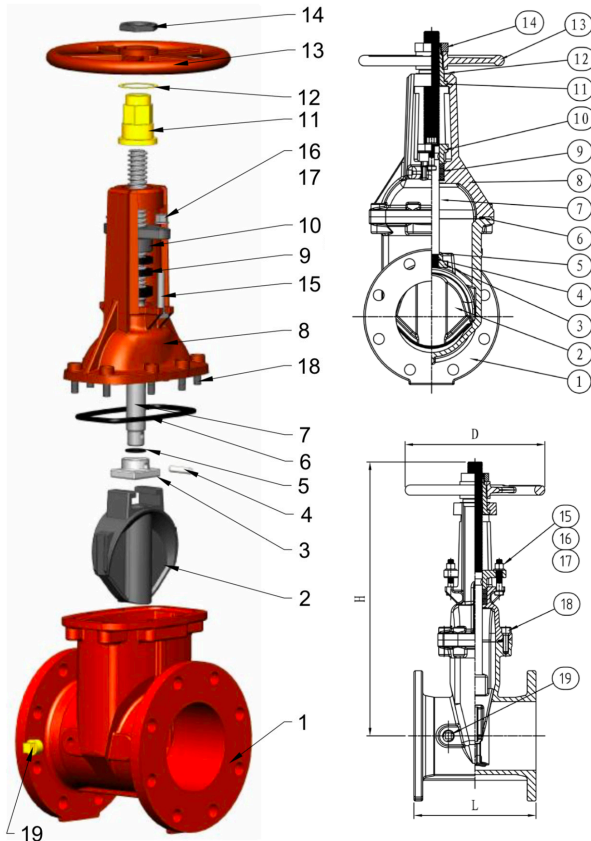

COMPONENTS

NO.	PART NAME	MATERIAL	ASTM SPECIFICATIONS
1	BODY	DUCTILE IRON	ASTM A536 65-45-12
2	WEDGE	DUCTILE IRON	EPDM ENCAPSULATED
3	WEDGE NUT	STAINLESS STEEL	AISI 304
4	PIN	STAINLESS STEEL	AISI 304
5	O-RING	RUBBER	EPDM
6	GASKET	RUBBER	EPDM
7	STEM	STAINLESS STEEL	AISI 304
8	BONNET	DUCTILE IRON	ASTM A536 65-45-12
9	PACKING	GRAPHITE	
10	GLAND	DUCTILE IRON	ASTM A536 65-45-12
11	YOKE NUT	BRONZE	ASTM C95200
12	WASHER	BRASS	
13	HANDWHEEL	DUCTILE IRON	ASTM A536 65-45-12
14	HANDWHEEL NUT	DUCTILE IRON	ASTM A536 65-45-12
15	BOLTS	STAINLESS STEEL	A2-70
16	NUTS	STAINLESS STEEL	A4-70
17	WASHERS	STAINLESS STEEL	AISI 304
18	BONNET BOLTS	STAINLESS STEEL	AISI 304
19	PLUG	MALLEABLE	

DIMENSIONS

SIZE	2"	2 1/2"	3"	4"	5"	6"	8"	10"	12"
L	7"	7 1/2"	8"	9"	10"	10 1/2"	11 1/2"	13"	14"
H (OPEN)	15"	16 5/8"	18 7/8"	21 5/8"	25 4/5"	29 1/8"	36 5/8"	44 1/2"	52"
H (CLOSED)	13"	13 3/4"	15 3/4"	17 3/4"	20 7/8"	23 1/4"	28 3/4"	34 3/4"	40 1/6"
D	7 1/4"	7 1/4"	10"	10"	12"	12"	14"	17 1/2"	17 1/2"

All information contained herein is supplied by manufacturer and deemed to be accurate. Information is subject to change without notice. Purchaser is responsible for proper installation, use and maintenance of product. Southern Valve & Fitting USA, Inc. passes on manufacturer's warranty but extends no other warranty. All products sold by Southern Valve & Fitting USA, Inc. are subject to its full terms and conditions of sales as published and available on request. Any warranty made extends to original purchaser and is not assignable or transferable.

816 Series OS&Y UL/FM Resilient Seated Gate Valve 14" - 24", Flanged Ends

SPECIFICATIONS

- COMPLIES WITH AWWA C515 STANDARD
- HEAVY DUTY HANDWHEEL AND ATTACHMENT NUT
- HIGH QUALITY GRAPHITE STEM SEAL
- NPT PLUG ON BODY
- FLANGES TO ANSI B16.1 CLASS 125 (OTHER FLANGE TYPES AVAILABLE ON REQUEST)
- UL LISTED FOR 14" - 24"
- FM APPROVED FOR 14" - 16"

WORKING PRESSURE

- 250 PSI FOR 14", 16", 18"
- 200 PSI FOR 20", 24"

WORKING TEMPERATURE

- 42°F TO 180°F

CORROSION PROTECTION

- FUSION BONDED EPOXY COATED INTERIOR AND EXTERIOR TO AWWA C550 STANDARD

INSTALLATION

- VALVES INSTALLED IN HORIZONTAL PIPING SYSTEMS SHOULD HAVE THE STEMS ORIENTED VERTICALLY
- VALVES INSTALLED IN VERTICAL PIPING SYSTEMS SHOULD HAVE THE STEMS ORIENTED HORIZONTALLY



COMPONENTS

PART NAME	MATERIAL	ASTM SPECIFICATIONS
BODY	DUCTILE IRON	ASTM A536 65-45-12
WEDGE	DUCTILE IRON, EPDM ENCAPSULATED	
WEDGE NUT	STAINLESS STEEL	AISI 304
STEM	STAINLESS STEEL	AISI 420
BONNET	DUCTILE IRON	ASTM A536 65-45-12
GASKET	RUBBER	EPDM
PACKING	GRAPHITE	COMMERCIAL
GLAND	DUCTILE IRON	ASTM A536 65-45-12
YOKE NUT	BRONZE	C62 C83600
HANDWHEEL	DUCTILE IRON	ASTM A536 65-45-12
HANDWHEEL NUT	DUCTILE IRON	ASTM A536 65-45-12
NPT PLUG	MALLEABLE IRON	COMMERCIAL
GLAND BOLT	STAINLESS STEEL	AISI 316
BONNET BOLT	CARBON STEEL	A307 B

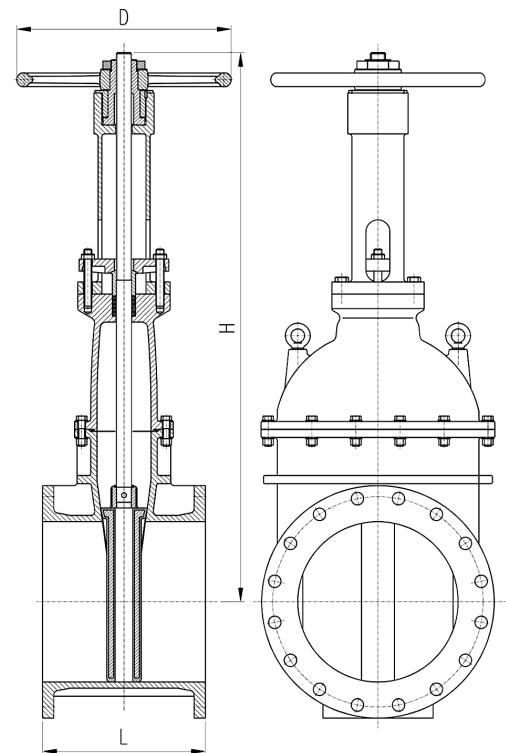

DIMENSIONS

(INCH)

SIZE	14"	16"	18"	20"	24"
L	15	16	17	18	20
H (OPEN)	61.97	70.31	79.53	89.61	102.36
H (CLOSE)	48.19	54.57	61.81	69.92	78.74
D	17.5	21	24	24	30